

Building Stable Op Amp Circuits

Introduction: Did you ever wonder how to calculate the stability of an op amp circuit? It's not obvious how a basic inverting circuit fits the classic feedback system block diagram shown in *Figure 1*. If the op amp is stable, shouldn't the circuit using it also be? (Not necessarily!) What about operation below unity gain? With just a few equations, you can understand basic op amp circuit stability.

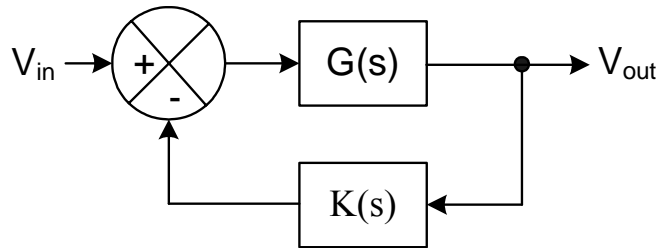

Figure 1 Classic Single Input, Single Output Feedback Loop Configuration

Classic Feedback Loop Stability: *Figure 1* is a drawing of the classic single input, single output feedback loop. The overall circuit gain of this loop (also called the closed loop gain) is calculated as follows:

From Inspection,

$$V_{out}(s) = V_{in}(s) G(s) - V_{out}(s) K(s) G(s)$$

Re-arranging,

$$\frac{V_{out}(s)}{V_{in}(s)} = \frac{G(s)}{1 + K(s)G(s)} \quad \text{Equation 1}$$

If the term in the denominator is zero, the circuit is unstable as V_{out}/V_{in} goes to infinity. Thus the circuit is unstable when $G(s)$ times $K(s)$ equals minus one. Since both G and K are functions of s (complex frequency), $G(s)$ times $K(s)$ can only be equal to minus one if the magnitude of the closed loop gain crosses zero dB (a gain of one) when the phase of $(G(s) K(s))$ is equal or more negative than -180° .

The phase margin is defined as $(180^\circ + \text{phase response})$ at the frequency at which the magnitude is zero dB. A phase margin designed to be at least 30° is usually the minimum a designer will accept. With a 30° phase margin, the circuit is likely to ring for a few cycles before reaching the set point. (Also, component variations may lower the actual phase margin.) A phase margin of 90° is generally over-damped (takes too long to reach the set point). Phase margins of 45 to 75° often provide a snappy response without much ringing.

Op Amp Circuits: Consider the standard non-inverting op-amp configuration of *Figure 2*.

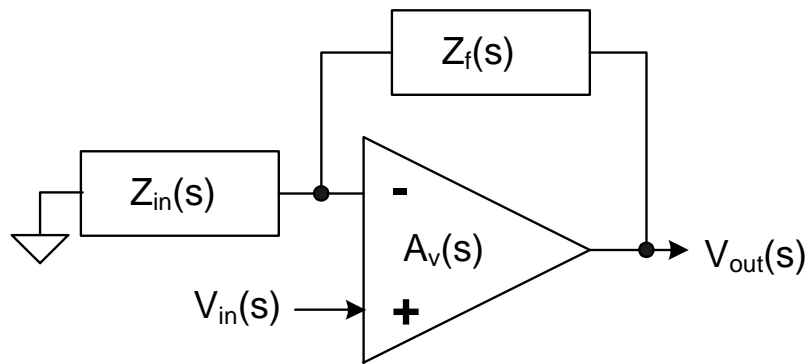

Figure 2 Non-Inverting Op Amp Configuration

Assume that the op amp has very high input impedance (no input leakage current) and very low output impedance (compared to Z_f). One can derive the transfer function:

Start with the equation for the op amp itself:

$$V_{out}(s) = A_v(s)(V_{plus} - V_{neg})$$

where

$$V_{plus} = V_{in}(s)$$

so

$$V_{out}(s) = A_v(s)(V_{in}(s) - V_{neg})$$

Next, write the node equation for the inverting input of the op amp (with no leakage current):

$$\frac{(V_{out} - V_{neg})}{Z_f} = \frac{V_{neg}}{Z_{in}}$$

$$\frac{V_{out}}{Z_f} = V_{neg} \left(\frac{1}{Z_f} + \frac{1}{Z_{in}} \right)$$

$$V_{neg} = V_{out} \frac{Z_{in}}{Z_{in} + Z_f}$$

Define $K(s)$ to be:
$$\frac{Z_{in}}{Z_{in} + Z_f}$$

Now substitute $K(s)$ and the expression for V_{neg} into the op amp equation:

$$V_{out}(s) = A_v(s)(V_{in}(s) - V_{out}(s)K(s))$$

$$V_{out}(1 + A_v(s)K(s)) = A_v(s)V_{in}(s)$$

$$\frac{V_{out}(s)}{V_{in}(s)} = \frac{A_v(s)}{1 + K(s)A_v(s)} \quad \text{Equation 2}$$

One quick check is to consider the case at low frequency when $A_v(s)$ is large. The denominator becomes simply $K(s)A_v(s)$, and V_{out}/V_{in} is approximately $1/K(s)$ or the familiar $1 + Z_f/Z_{in}$.

Note that *Equations 1 and 2* are of the same form. One can re-draw the basic non-inverting op amp configuration to what is shown in *Figure 3*.

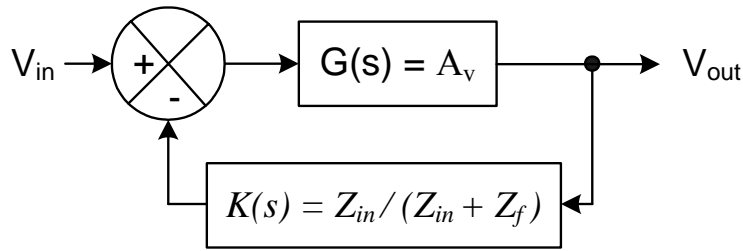

Figure 3 Classic Single Input, Single Output Feedback Loop Configuration for the Non-Inverting Op Amp Configuration

Again, this circuit is stable if the phase of $(A_v Z_{in} / (Z_{in} + Z_f))$ is less negative than -180° at the frequency where the magnitude of this term is zero dB. Using *Figure 4*, you can visualize the open loop gain by disconnecting Z_{in} and Z_f from the op amp's inverting input. Ground the inverting input and take the output (V_{fb}) at the junction of Z_{in} and Z_f (now a voltage divider). By inspection, the open loop gain is (again):

$$\frac{V_{fb}(s)}{V_{in}(s)} = \frac{A_v(s)Z_{in}}{Z_{in} + Z_f} = A_v(s)K(s)$$

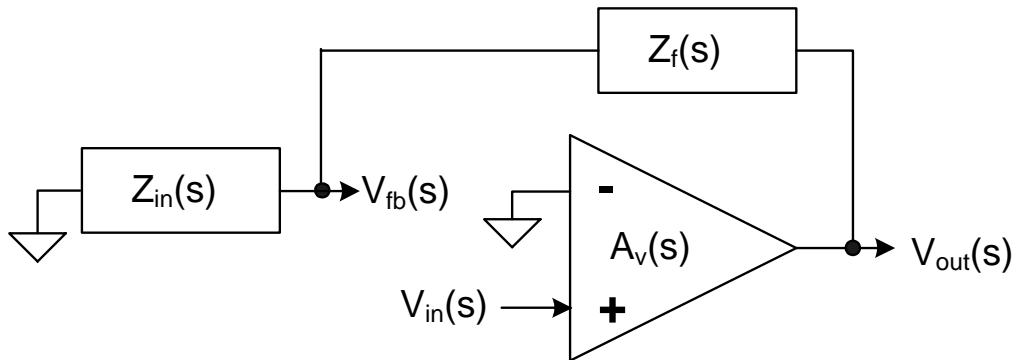

Figure 4 Opening the Loop with for a Non-Inverting Op Amp Configuration

Now consider the inverting circuit of *Figure 5*.

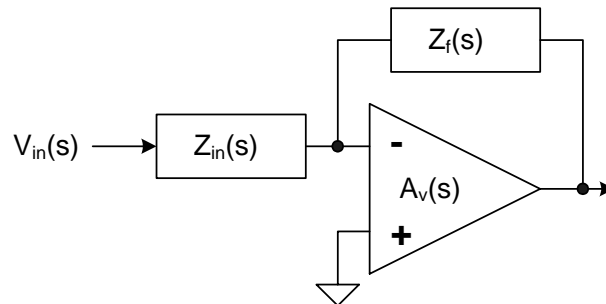

Figure 5 Basic Inverting Op Amp Configuration

One can derive the closed-loop gain in a similar fashion to the non-inverting circuit of *Figure 2* resulting in:

$$\frac{V_{out}(s)}{V_{in}(s)} = \frac{A_v(s)(K(s) - 1)}{1 + K(s)A_v(s)} \quad \text{Equation 3}$$

Where $K(s)$ is still defined to be: $\frac{Z_{in}}{Z_{in} + Z_f}$

The low-frequency gain is $1 - 1/K(s)$ or the familiar $-Z_f/Z_{in}$. The only difference with the non-inverting op amp circuit is the $(K(s) - 1)$ term in the numerator. In the classic feedback loop configuration, this is equivalent to adding a block at the input, shown in *Figure 6*. Note that $L(s)$ does not have any effect on the stability of the feedback loop itself.

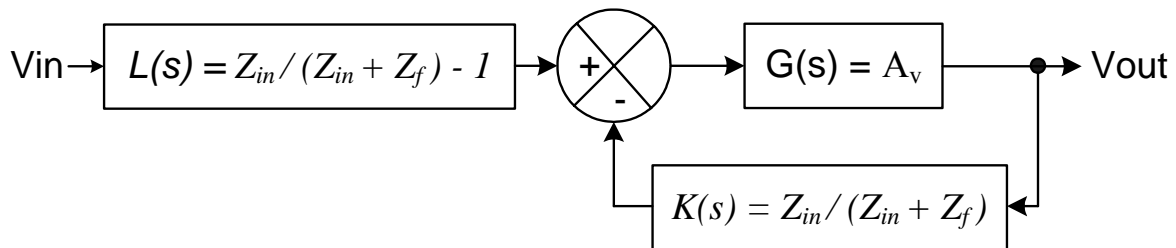

Figure 6 Classic Feedback Loop with Input Attenuating Block

More to the point, both the basic non-inverting and inverting op amp configurations have the same stability criteria! In the simplest implementations of these circuits, both Z_{in} and Z_f are resistors (R_{in} and R_f). For stability, one only needs to consider the gain of the op amp itself, scaled up and down by the gain ($R_{in} / (R_{in} + R_f)$).

Some op amps require some minimum gain greater than one (e.g., ten) to be stable. For these op amps, the phase margin of the op amp itself is either close to zero or negative at unity gain. However, a decade lower in frequency than the zero dB point of the op amp itself, the phase margin may be acceptable. Many other modern op amps are “unity gain stable.” Unity gain stable op amps have adequate phase margin in a buffer configuration (*Figure 7* below).

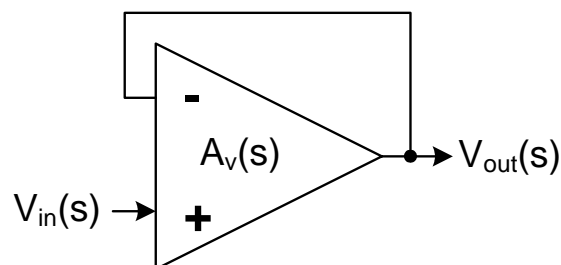
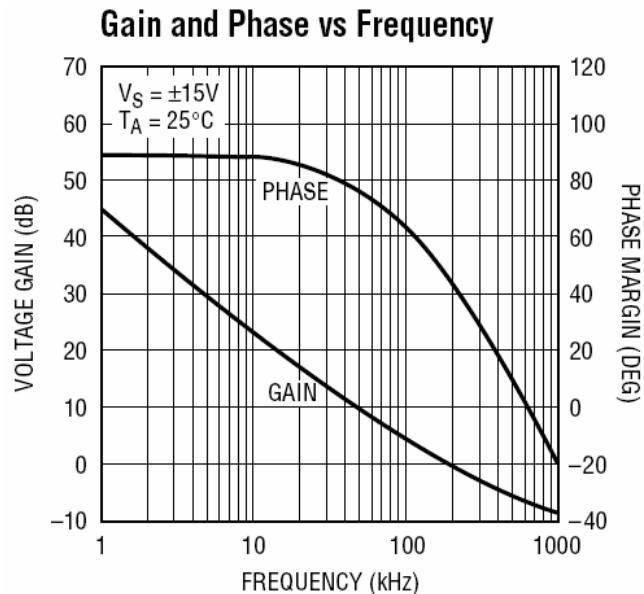

Figure 7 Op Amp Buffer Circuit

One non-intuitive result is that as the circuit gain diminishes below unity, $K(s)$ approaches one for both inverting and non-inverting circuit configurations. In an inverting configuration with at a gain of one, $Z_f = Z_{in}$, and K is $1/2$. If the gain is one half, K is $1/3$. As K decreases, the circuit bandwidth approaches that of the op amp itself in a buffer configuration.

Consider the unity-gain stable op amp, whose open loop gain is shown in *Figure 8* below. In this figure, the gain crosses 0dB at approximately 175kHz. At 175kHz, the figure shows that the phase margin is approximately 43°. So if this op amp were operated in a buffer configuration, it would have a phase margin of 43°.

If the op amp were used in an inverting configuration with a gain of one, K would be 0.5 or -6dB ($20 \log_{10}(0.5)$). The open loop gain in this inverting configuration would be the open loop gain of the op amp itself shifted downward by 6dB. The 0dB point of the open loop gain would then be ~90kHz, and the phase margin would be ~63°.



*Figure 8 Open Loop Gain for the Linear Tech LT1462
(This plot shows Phase Margin Instead of Phase Shift)*

For contrast, consider the LT1886 (see *Figure 9* below) which is specified to be stable only for closed loop gains greater than or equal to 10. At an inverting gain of 10, $K = 1/9$ or -19dB ($20 \log_{10}(1/9)$). The figure shows that the 0dB point is at ~300MHz. Dropping the open loop gain curve of the op amp by 19dB drops the 0dB point to about 60MHz. At 60MHz, the phase margin becomes about 60° instead of -60°.

Gain and Phase vs Frequency

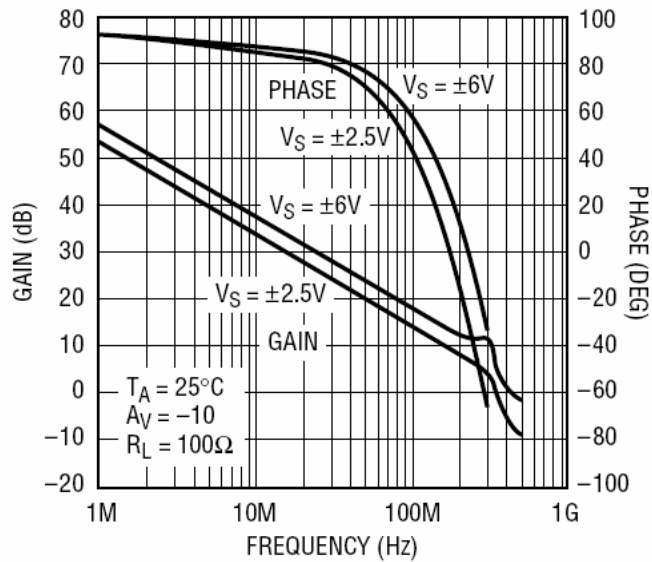

1886 G10

Figure 9 Open Loop Gain for the Linear Tech LT1886
(This plot shows Phase Margin Instead of Phase Shift)

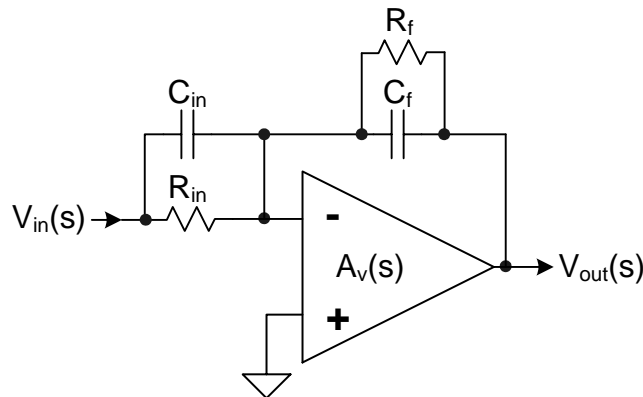

Figure 10 Integrator/Differentiator Circuit

Finally, consider the integrator/differentiator circuit shown in *Figure 10* above. One can derive the feedback and input impedances to be:

$$Z_f = \frac{R_f}{(1 + sR_fC_f)} \quad \text{and} \quad Z_{in} = \frac{R_{in}}{(1 + sR_{in}C_{in})}$$

In now deriving $K(s)$, one can see the low-frequency resistive attenuation in the numerator (when the capacitors are open circuits) along with a zero and a pole:

$$\Rightarrow K(s) = \frac{Z_{in}}{Z_{in} + Z_f} = \frac{\alpha(1 + s / K_{Z1})}{(1 + s / K_{P1})}$$

where

Equation 5

$$\alpha \equiv \frac{R_{in}}{(R_{in} + R_f)}, K_{Z1} \equiv \frac{1}{R_f C_f}, K_{P1} \equiv \frac{(R_{in} + R_f)}{(R_{in} R_f C_f + R_f R_{in} C_{in})}$$

Generally, it is possible to determine the DC gain, poles and zeroes of an op amp either directly from the data sheet or to infer them from the open loop frequency response. For instance, $A_v(s)$, the op amp gain, might be of the form:

$$A_v(s) = \frac{DC_{gain}}{(1 + \frac{s}{P_1})(1 + \frac{s}{P_2})(1 + \frac{s}{P_3})} \quad \text{Equation 6}$$

Multiplying $K(s)$ by $A_v(s)$ yields the open loop gain. The closed loop gain can be calculated using Equation 3 above (in conjunction with Equation 5 and Equation 6). $K(s)$ and $A_v(s)$ have numerators (abbreviated as *num* below) and denominators (abbreviated as *den* below) that are polynomials of s . So Equation 3 can be re-written as:

$$\frac{V_{out}(s)}{V_{in}(s)} = \frac{A_v(s)(K(s) - 1)}{1 + K(s)A_v(s)} = \frac{A_{vnum}(\frac{K_{num}}{K_{den}} - 1)}{A_{vden}(1 + \frac{K_{num}}{K_{den}} \frac{A_{vnum}}{A_{vden}})} = \frac{A_{vnum}(K_{num} - K_{den})}{A_{vden}K_{den} + K_{num}A_{vnum}}$$

or

$$\frac{V_{out}(s)}{V_{in}(s)} = \frac{DC_{gain}(\alpha(1 + \frac{s}{K_{Z1}}) - (1 + \frac{s}{K_{P1}}))}{(1 + \frac{s}{P_1})(1 + \frac{s}{P_2})(1 + \frac{s}{P_3})(1 + \frac{s}{K_{P1}}) + DC_{gain} \alpha(1 + \frac{s}{K_{Z1}})}$$

Notice that at low frequency (where DC_{gain} is large and s is small), the closed loop gain becomes $(\alpha - 1)/\alpha$ which can be reduced to the ubiquitous R_f/R_{in} .

One would need to plug in some actual values to evaluate the stability (or instability) of this circuit. The whole point was to show how to set up the open and closed loop equations with complex input and/or feedback impedances. Matlab is one of several programs that can be used to plot the open and closed loop gains.

The open and closed loop equations provide a solid basis for building stable op amp circuits. Of course, (happily) there is more to learn. For example, much has been written on how to stabilize op amp circuits with excessive capacitive loading. My favorite reference on op amp circuits is Stout & Kaufman's *Handbook of Operational Amplifier Circuit Design*, ©1976, McGraw Hill Inc.

About the author:

Kurt Aronow has been designing circuits since 1981. He currently works on medical devices at Kestrel Labs in Boulder, Colorado. He can be reached at www.kurtaronow.com.